

Instructions

Digital homogenizer pressure gauge

PG110-X



attestation

ISO 9001:2015

Please read this instruction manual carefully before installation



Content

1. Introduction.
2. Scope and application field.
3. Transportation and storage.
4. Install/Uninstall
5. Technical data
6. Appearance size
7. Operating Instructions
8. Selection Guide

Introduction

PG110X series digital display pressure gauge can realize the setting of zero point, full scale, decimal point, damping time, switch alarm and alarm direction through single-key programming, without adjusting the potentiometer; high precision, good stability, perfect performance, etc. It has the characteristics of high reliability and long-term stability, and combines the world's leading micro-processing technology and advanced analog-to-digital conversion algorithm to meet the requirements of high precision and low power consumption. Large-screen LCD display technology is adopted to make the data clear and easy to read. Corrosion-resistant, anti-vibration, can be applied in a variety of complex environments

Scope and application field

PG110-X series adopts LCD liquid crystal display and is widely used in food processing industries such as high-pressure homogenizers and high-pressure fine bubble breakers.

Transport and storage

PG110-X series pressure gauges are usually packaged individually, and the sensing diaphragm is protected by a protective cap. This protective cap should be tightened at any time during storage, and only opened when it is used for installation.

Install/Uninstall

When installing and disassembling the pressure gauge, ensure that the equipment is operated without pressure. Because the gauge head can rotate 360 degrees, it is easy for the operator to read the pressure when the gauge head is reading.

Technical data

Pressure range	0~100MPa, 0~150MPa, 0~200MPa
Measuring class	1.0%FSO
Supply voltage	9VDC
Process connection	M20×1.5
Display type	LCD liquid crystal display maximum value display 1999 bar minimum value display 10bar
Operating temperature	-15~70°C
Overload pressure	150%FSO
Measuring medium	Fluids Compatible with 316L Stainless Steel

Outline drawing

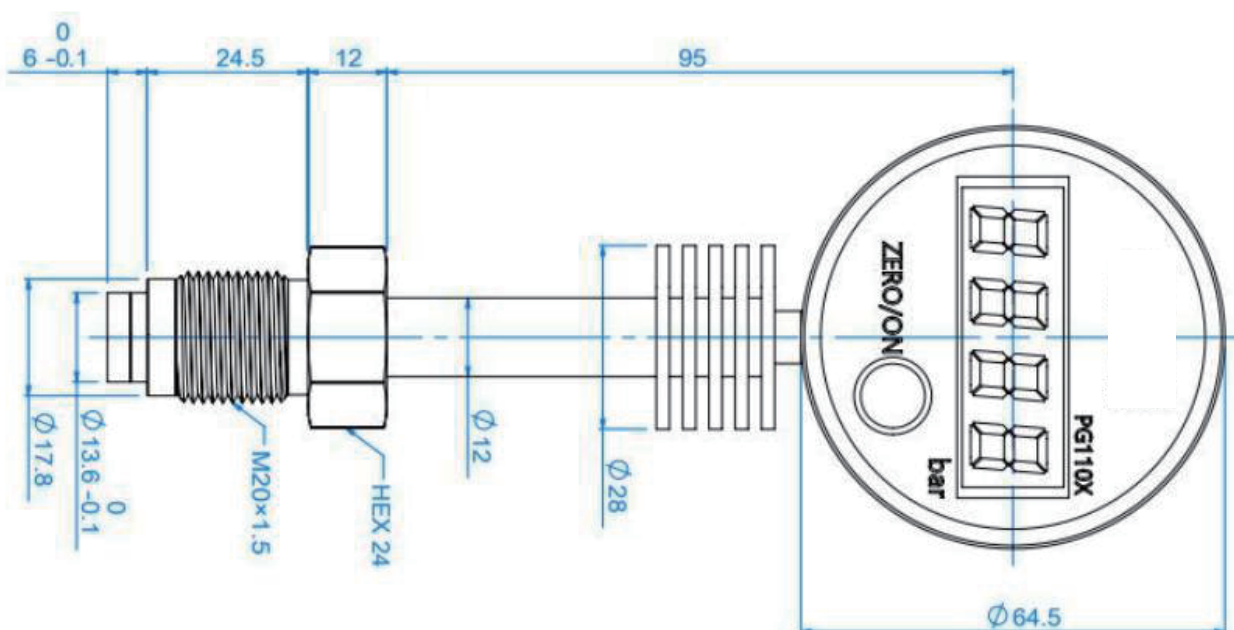

Operating Instructions

Press and hold the ZERO/ON button for 3 seconds to return to zero.

In the off state, press ZERO to turn on the machine, and when there is no pressure fluctuation, it will automatically turn off in 3 minutes.

Selection Guide

Serie code		PG110-X	X	-	X
Product type	0~100MPa		10H		
	0~150MPa		15H		
	0~200MPa		20H		
Pressure connection	M20×1.5				null
	G1/2				G1/2
	G3/4				G3/4
	G1				G1